



## Powered Subwoofer



## XLS112 Owner's Manual

The lightning flash with arrowhead, within an equilateral triangle, is intended to alert the user to the presence of uninsulated "dangerous voltage" within the product's enclosure that may be of sufficient magnitude to constitute a risk of electric shock to persons.



**AVIS** RISQUE DE CHOC ELECTRIQUE - NE PAS OUVRIR.

The exclamation point within an equilateral triangle is intended to alert the user to the presence of important operating and maintenance (servicing) instructions in the literature accompanying the appliance.

**WARNING - TO REDUCE RISK OF FIRE OR ELECTRICAL SHOCK, DO NOT EXPOSE THIS EQUIPMENT TO RAIN OR MOISTURE.**

**NO USER-SERVICEABLE PARTS INSIDE. REFER SERVICING TO QUALIFIED PERSONNEL.**

To prevent the risk of electric shock, do not remove cover or back. No user-serviceable parts inside.

## IMPORTANT SAFETY INSTRUCTIONS!

### **PLEASE READ THEM BEFORE OPERATING THIS EQUIPMENT.**

1. Read these instructions.
2. Keep these instructions.
3. Heed all warnings.
4. Follow all instructions.
5. Do not use this apparatus near water.
6. Clean only with a dry cloth.
7. Do not block any ventilation openings. Install in accordance with the manufacturer's instructions.
8. Do not install near any heat sources such as radiators, heat registers, stoves, or other apparatus (including amplifiers) that produce heat.
9. Do not defeat the safety purpose of the polarized or grounding-type plug. A polarized plug has two blades with one wider than the other. A grounding type plug has two blades and a third grounding prong. The wide blade or the third prong are provided for your safety. If the provided plug does not fit into your outlet, consult an electrician for replacement of the obsolete outlet.
10. Protect the power cord from being walked on or pinched particularly at plugs, convenience receptacles, and the point where they exit from the apparatus.
11. Only use attachments/accessories specified by the manufacturer.
12. Use only with the cart, stand, tripod, bracket, or table specified by the manufacturer, or sold with the apparatus. When a cart is used, use caution when moving the cart/apparatus combination to avoid injury from tip-over. 
13. Unplug this apparatus during lightning storms or when unused for long periods of time.
14. Refer all servicing to qualified service personnel. Servicing is required when the apparatus has been damaged in any way, such as power-supply cord or plug is damaged, liquid has been spilled or objects have fallen into the apparatus, the apparatus has been exposed to rain or moisture, does not operate normally, or has been dropped.
15. Do not expose this equipment to dripping or splashing and ensure that no objects filled with liquids, such as vases, are placed on the equipment.
16. To completely disconnect this equipment from the a.c. mains, disconnect the power supply cord plug from the a.c. receptacle.
17. The mains plug of the power supply cord shall remain readily operable.
18. This apparatus is capable of producing high sound pressure levels. Continued exposure to high sound pressure levels can cause permanent hearing impairment or loss. User caution is advised and ear protection is recommended when playing at high volumes.
19. Do not operate this apparatus without the front panel grille attached to the cabinet.

---

## Thank You

Your decision to own this McIntosh XLS112 Powered Subwoofer ranks you at the very top among discriminating music listeners. You now have “The Best.” The McIntosh dedication to “Quality,” is assurance that you will receive many years of musical enjoyment from this unit.

Please take a short time to read the information in this manual. We want you to be as familiar as possible with all the features and functions of your new McIntosh.

## Please Take A Moment

The serial number, purchase date and McIntosh Dealer name are important to you for possible insurance claim or future service. The spaces below have been provided for you to record that information:

**Serial Number:** \_\_\_\_\_

**Purchase Date:** \_\_\_\_\_

**Dealer Name:** \_\_\_\_\_

## Technical Assistance

If at any time you have questions about your McIntosh product, contact your McIntosh Dealer who is familiar with your McIntosh equipment and any other brands that may be part of your system. If you or your Dealer wish additional help concerning a suspected problem, you can receive technical assistance for all McIntosh products at:

McIntosh Laboratory, Inc.  
2 Chambers Street  
Binghamton, New York 13903  
Phone: 607-723-1545  
Fax: 607-772-3308

## Customer Service

If it is determined that your McIntosh product is in need of repair, you can return it to your Dealer. You can also return it to the McIntosh Laboratory Service Department. For assistance on factory repair return procedure, contact the McIntosh Service Department at:

McIntosh Laboratory, Inc.  
2 Chambers Street  
Binghamton, New York 13903  
Phone: 607-723-3515  
Fax: 607-723-1917

## Table of Contents

Safety Instructions .....	2
Thank You and Please Take a Moment.....	3
Technical Assistance and Customer Service .....	3
Table of Contents .....	3
Important Information .....	4
Connector Information .....	4
Introduction .....	4
Performance Features .....	5
Dimensions .....	6
Installation .....	8
Rear Panel Connections .....	9
How to Connect .....	10
How to Operate .....	12
Specifications .....	14
Packing Instruction .....	15



## Important Information

1. The following Connecting Cable is available from the McIntosh Parts Department:  
**Power Control Cable Part No. 170-202**  
Six foot, 2 conductor shielded, with two 1/8 inch stereo mini phone plugs.
2. For additional connection information, refer to the owner's manual(s) for any component(s) connected to the XLS112.
3. In the event that the XLS112 over heats, due to improper ventilation and/or high ambient temperature, the protection circuit will activate placing it in the Standby Mode. The Rear Panel Status LED Indicator will illuminate Red and the audio will be muted. When the XLS112 has returned to a safe operating temperature, normal operation will resume.
4. The XLS112's Power Control Input will function within a 5 to 20 DC Voltage range.
5. To avoid damage, do not connect the speaker level output terminals from any receiver, amplifier or integrated amplifier to the inputs of the XLS112 Powered Subwoofer.

## Connector Information

### XLR Connectors

Below is the Pin configuration for the XLR Balanced Input and Output Connectors on the XLS112. Refer to the diagram for connection:

- PIN 1: Shield/Ground
- PIN 2: + Signal
- PIN 3: - Signal

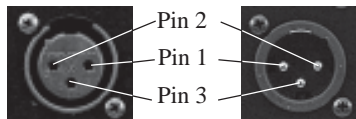

### Power Control Connector

The XLS112 Power Control Input/Output Jacks provide Power On/Off Signals when connected to other McIntosh Components. A 1/8 inch stereo mini phone plug is used for connection to the Power Control Input/Output on the XLS112.

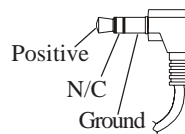

## Introduction

The McIntosh XLS112 Powered Subwoofer is designed for Home Theater and Music Reproduction. It has a 12 inch LD/HP<sup>1</sup> woofer, a 400 watt amplifier and built-in high and low pass filters.

The XLS112 Powered Subwoofer's performance is equivalent to the quality of McIntosh's legendary line of Amplifiers, Preamplifiers, Signal Processors, Signal Sources and Loudspeakers, without imparting distortion or coloration of its own. It also complements the capabilities and the remarkably low distortion of McIntosh Power Amplifiers.

Many of today's Loudspeakers are designed only for Home Theater applications. Not so with the XLS112. It is also designed for the accurate reproduction of the low frequencies contained in music. Motion picture sound effects, explosions, and vehicle crashes require a wide dynamic range and high sound levels. These sounds are such that a speaker system having moderate distortion would reproduce them with little audible difference. This is not true with the reproduction of music. Music is by nature and definition harmonious. To reproduce it accurately, all forms of distortion, both harmonic and intermodulation, must be kept to a minimum. This has been the result of the design of the new McIntosh XLS112 Powered Subwoofer. Each component in the device has been carefully designed for durability, efficiency, and above all, low distortion. The McIntosh XLS112 Powered Subwoofer will reproduce music accurately and function as an excellent Home Theater Powered Subwoofer.

<sup>1</sup>LD/HP Pat. No. 5,151,943

### Performance Features

---

- **Patented LD/HP Technology**

The McIntosh Loudspeaker Element features the patented LD/HP motor structure. This design, when compared to conventional Loudspeaker Elements, reduces distortion significantly. It also increases power handling and efficiency.

- **Large Woofer with Integral Heat Sink**

Massive dual magnets with thick front and back plates provide an incredible heat sink for the voice coil. The voice coil itself is wound on a 3" diameter aluminum bobbin to further aid in the dissipation of heat. The ability to dissipate heat greatly improves the driver's capacity to perform at high power levels and not suffer from power compression.

- **Rigid Woofer Framework**

A black powder coated, die cast aluminum basket is used as the framework for the driver. Such framework is necessary to keep the driver's moving components aligned during the long excursions a subwoofer can produce.

- **Shielded Magnetic Field**

The XLS112 may be used in Home Theater Installations near a television receiver or monitor without causing the television image to degrade. McIntosh has designed special shielding around the magnetic structure of the XLS112's Loudspeaker Element to prevent interference.

- **High Power and Low Distortion**

The XLS112's 400 Watt Amplifier has very Low Total Harmonic Distortion (THD). This 0.07% THD rating combined with the low distortion of the McIntosh LD/HP Driver provides exceptionally smooth and clean low frequency response.

- **Power Guard**

The patented McIntosh Power Guard circuit prevents the XLS112's Amplifier from being over driven into clipping, with its harsh distorted sound that can also damage your valuable Loudspeaker.

- **Remote Power Control**

The turn-on method uses a standard McIntosh Power Control jack to receive a turn-on signal from a McIntosh Control Center. The alternate turn-on method for the XLS112 utilizes signal-sensing circuitry.

- **Signal Sensing Circuitry**

In addition to the McIntosh Remote Power Control feature, the XLS112 utilizes signal-sensing circuitry. This signal-sensing circuitry is beneficial when the XLS112 is to be located at a great distance from the pre-amp and running an additional Power Control Cable for remote turn-on is not feasible.

- **Phase Switch**

The Phase Switch can be set to 0° or 180° to avoid phase cancellation.

- **Balanced and Unbalanced Inputs/Outputs**

Balanced connections guard against induced noise and allow long cable runs without compromising sound quality.

- **Variable Low Pass Filter**

The variable Low Pass Filter selects the low frequencies sent to the XLS112's Power Amplifier when used with a full range source signal. This filter can be switched out of the signal path in Home Theater Systems.

- **Sentry Monitor and Thermal Protection**

McIntosh Sentry Monitor power output stage protection circuits ensure the XLS112 will have a long and trouble free operating life. Built-in Thermal Protection Circuits guard against overheating.

- **Heavy Duty Power Supply**

The XLS112 incorporates a regulated Power Supply, special R-Core Power Transformer and extra large filter capacitors. All together these design features ensure stable noise free operation even though the power line varies.

- **Gold Plated Input Connectors**

The XLS112 Input Connectors are gold plated for superior corrosion resistance and high electrical conductivity.

- **Special Enclosure**

The XLS112 Enclosure is a combination of thick extruded aluminum metal sides and rear panel with a textured black powder coated finish. The front, top and bottom of the enclosure is made from thick MDF covered with a thermal vacuum formed durable surface also in a textured black finish.



## Dimensions

The following dimensions can assist in determining the best location for your XLS112 Powered Subwoofer. There is additional information on page 8 pertaining to installing the XLS112.

*Note: The XLS112 is supplied with optional adjustable feet, four Tiptoes and four Glides. If they are used with the XLS112 please allow for the added height.*

**Front View of  
XLS112 with  
Grille Removed**

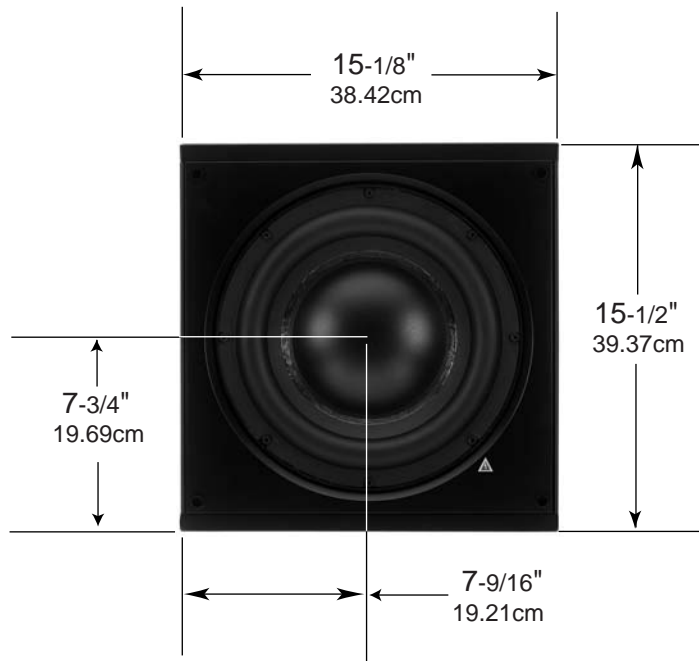

**Rear View of  
XLS112**

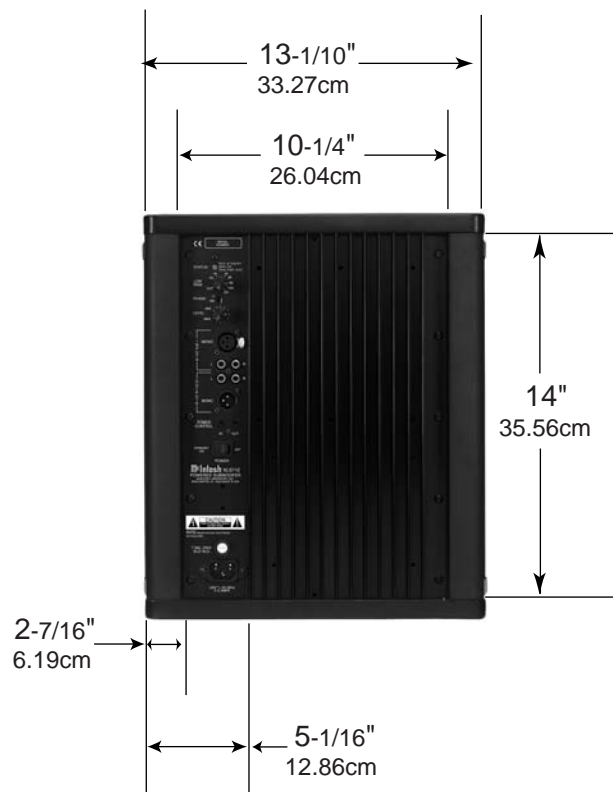

Top View of XLS112

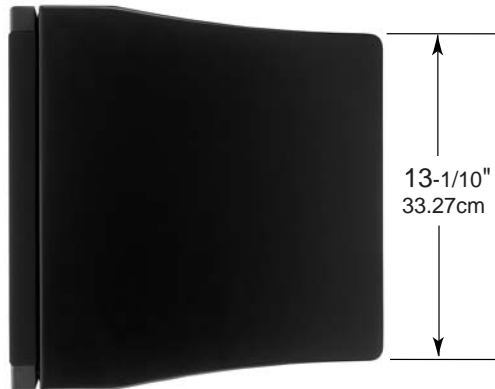

Side View of XLS112



Bottom View of XLS112

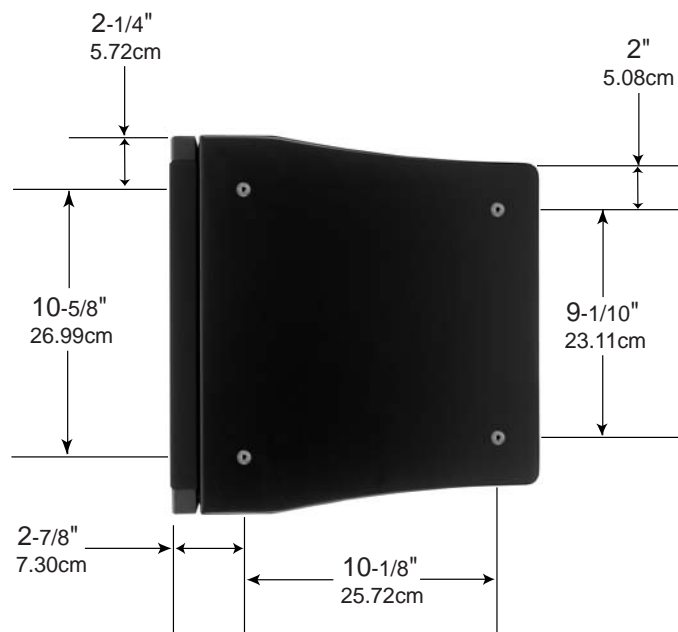

## Installation

### Locating the XLS112

Always provide adequate ventilation for the XLS112 Powered Subwoofer. Cool operation ensures the longest possible life for any electronic instrument. An installation should provide at least 2 inches spacing on all sides of the XLS112, so airflow is not obstructed.

The optimal method for selecting speaker locations includes the use of a real time spectrum analyzer (RTA) operated by an experienced system installer. An uncompromising installation would take into consideration the floor, wall and ceiling coverings, the type and placement of furniture and can even include the architectural design of the room and its construction materials. Frequencies 80Hz and below reproduced by the XLS112 Powered Subwoofer are non-directional and will sound best located toward the front of the room and away from corners. It is not necessary to aim the front of the XLS112 directly at the listener. Refer to figure 2.

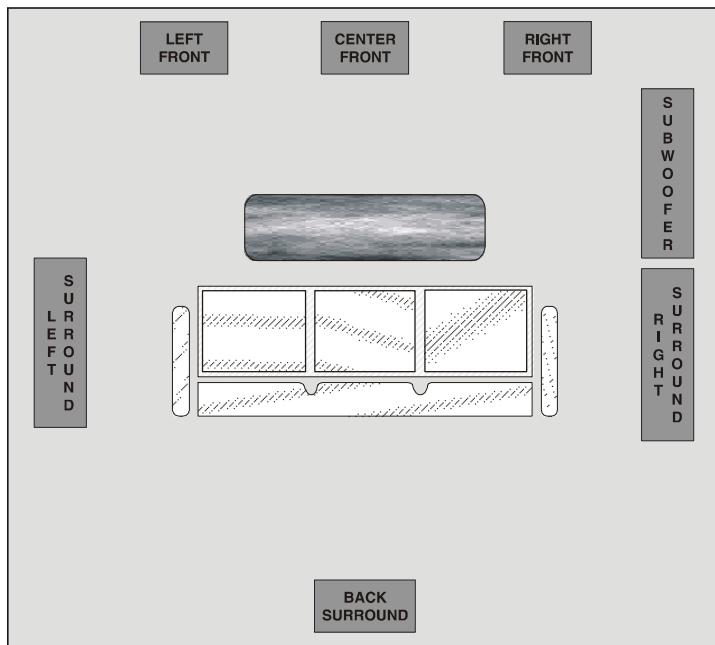
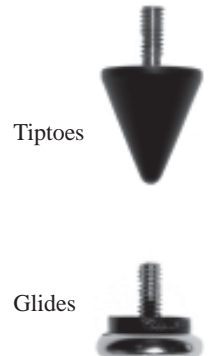

Figure 2

### Optional Feet

Two sets of optional feet (four Tiptoes and four Glides) are supplied with the XLS112 Powered Subwoofer. To prevent crushing carpet use the Tiptoe spikes; to protect non-carpeted flooring use the chrome Glides. Both the Glides and Tiptoes have a threaded shaft and locking nut that screw into the tapped holes in the bottom of the XLS112. The feet can be independently adjusted to compensate for uneven flooring.





STATUS LED Indicator illuminates RED when the XLS112 is in the Standby Mode, GRN (Green) when Power is ON and ORN (Orange) during the time the Power Guard Circuit has activated

LOW PASS Filter selects the low frequencies sent to the XLS112's Power Amplifier

PHASE reversing switch to help avoid phase cancellation

LEVEL Control allows adjustment of acoustic output to balance with the other Loudspeakers

INPUTS L (Left) and R (Right) Unbalanced Jacks or MONO (Monaural) Balanced Connector accepts signal from the output of a A/V Control Center or Audio Control Center

OUTPUTS L (Left) and R (Right) Unbalanced Jacks or MONO (Monaural) Balanced Connector provides signal to the next Powered Subwoofer or Power Amplifier

POWER CONTROL IN receives turn on/off signals from a McIntosh component and the POWER CONTROL OUT sends the turn on/off signal to the next McIntosh component

POWER Switch Turns AC power Standby/On and Off

Main Fuse holder, refer to information on the back panel of your XLS112 to determine the correct fuse size and rating

Connect the XLS112 power cord to a live AC outlet. Refer to information on the back panel to determine the correct voltage





## How to Connect

The McIntosh XLS112 Powered Subwoofer may be turned On or Off by two different methods. The preferred method is to utilize the Power Control Signal from a McIntosh A/V Control Center or Audio Control Center. If the Power Control Signal is not available, the XLS112 has built-in signal-sensing circuitry which will automatically turn-on the Powered Subwoofer.

1. Connect a power control cable from the McIntosh A/V Control Center or Audio Control Center Power Control Out Jack to the McIntosh XLS112 POWER CONTROL IN Jack.

2. Connect a power control cable from the McIntosh XLS112 POWER CONTROL OUT Jack to the McIntosh Power Amplifier Control In Jack.

*Notes: 1. If two or more McIntosh XLS112 Powered Subwoofers are being used in the same system, connect the POWER CONTROL OUT from the first XLS112 to the next XLS112 POWER CONTROL IN Jack and then onto the McIntosh Power Amplifier.*

*2. The XLS112's Power Control Input will function with 5 to 20 Volts DC applied.*

3. Connect a Balanced Audio Cable from the McIntosh A/V Control Center or Audio Control Center Subwoofer Out to the McIntosh XLS112 MONO INPUT(S).

*Notes: 1. If two or more McIntosh XLS112 Powered Subwoofers are being used in the same system, connect a second Audio Cable from the first XLS112 MONO OUTPUT(S) to the next XLS112 MONO INPUT(S).*

*2. The unbalanced L (Left) or R (Right) INPUT(S) jack may be connected instead of the Balanced Input jack.*

*3. If the input signal is insufficient for proper system balance, connect an unbalanced cable from the McIntosh A/V Control Center or Surround Decoder Subwoofer Out to a "Y" adapter and connect the "Y" adapter outputs to both the L (Left) and R (Right) INPUT Jacks. This will increase the input gain of the XLS112 by 6dB.*

4. Attach to the Front Panel the supplied Loudspeaker Grille.
5. Connect the XLS112 power cord to an active AC outlet.

McIntosh A/V Control Center

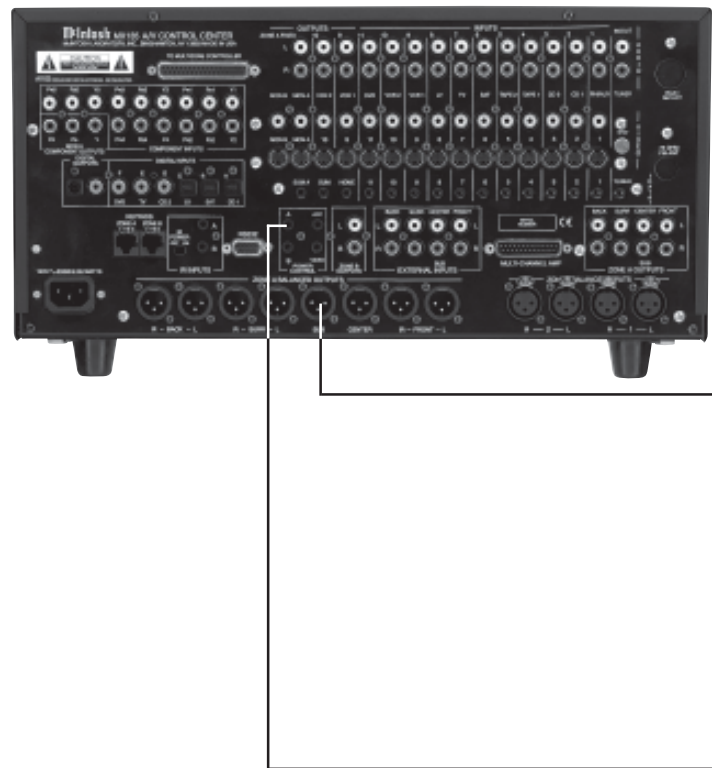

McIntosh Seven Channel Power Amplifier





## How to Operate

### Level Control

Start with the LEVEL CONTROL in the center position and perform the system level calibration on the A/V Control Center or Surround Decoder for the subwoofer level. If the subwoofer level can not be set, adjust the XLS112's LEVEL CONTROL to provide adequate range during calibration. Refer to figure 3.



Figure 3

*Note: If the Control is set to maximum and additional output is needed refer to note 3.2 on page 10.*

### Low Pass

This control determines from what frequency and below the XLS112 will reproduce sound when the information is present in the audio signal.

When the XLS112 is used with a discrete Sub Out from a Home Theater Control Center, the LOW PASS Control should be set to OUT, as the signal should contain only low frequency information. Refer to figure 4.



Figure 4

### Phase

The PHASE Switch sets the acoustic output phase of the XLS112 to either 0 or 180 degrees relative to its input. This switch is to help avoid phase cancellation (characterized by a loss of bass information) between the XLS112 and any other low frequency producing speaker in the system. Careful listening with this circuit switched to 0 and then listening with it switched to 180 will help you determine if this effect will be beneficial to the system. Set the switch for the desired bass output. Refer to figure 5.

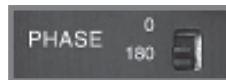

Figure 5

### Power

When the POWER SWITCH is set to the OFF position, the XLS112 can not be turned on by a Remote Power Control input or audio input signal sensing. Refer to figure 6.



Figure 6

### Remote Power Control

The XLS112's Power Control Circuitry uses the turn-on signal from a McIntosh Control Center or Preamplifier to switch On and Off. When a Power Control Cable is connected between the Control Center or Preamplifier and the XLS112, the audio signal-sensing circuit is disabled and the XLS112 will automatically turn-on when the Control Center or Preamplifier is on. The XLS112 also has a Power Control OUTPUT jack for triggering additional subwoofers or other McIntosh component(s).

When there is no Power Control Cable connected to the XLS112, the audio signal-sensing circuitry is active and automatically switches power On and Off. This occurs when a music signal is detected at the Line INPUT(s). A time delay of thirty minutes is incorporated in the circuit to prevent the XLS112 from turning off during a music or movie passage where there is little low frequency activity.

### Status Indicator

The STATUS Indicator is a tri-color LED and illuminates a different color depending upon the current operating condition of the XLS112. When the LED is illuminated Red the XLS112 is in the Standby Mode. The LED will change to Green in color when the XLS112 is switched on either by a Power Control Signal or the Audio Signal Sensing Circuit has detected a low frequency audio signal present at the Input jack(s). During peaks in the audio signal the LED may change from Green in color to indicate the built-in Power Guard Circuit has momentarily activated. Refer to figure 7.



Figure 7

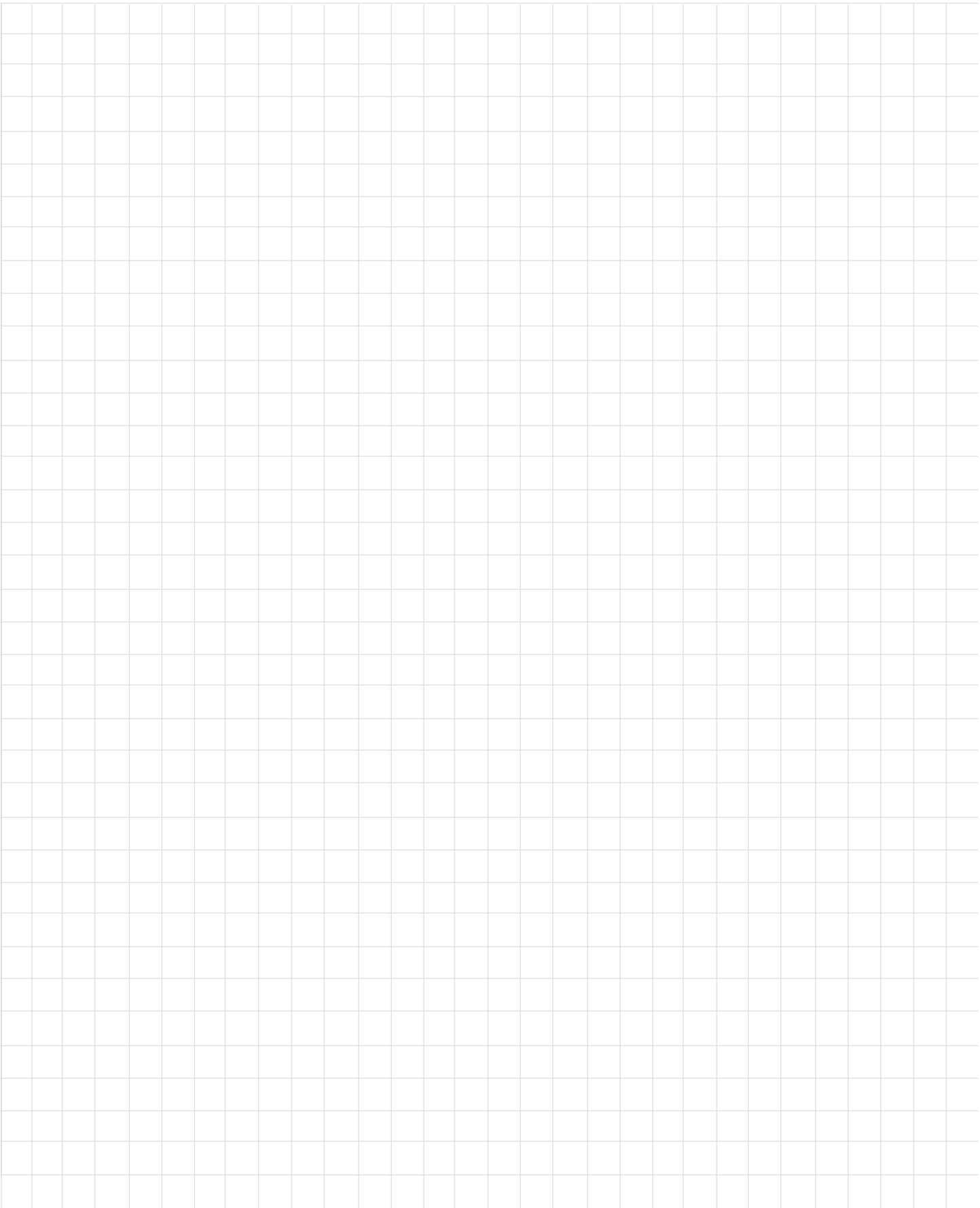



## Specifications

---

### Driver Complement

12 inch LD/HP Woofer

### Frequency Response

35Hz to 200Hz ( $\pm 3$ dB)

### Maximum Sound Pressure Level

115dB

### Power Output

400 Watts Sine Wave Continuous Power

### Total Harmonic Distortion (Power Ampfier)

Maximum Total Harmonic Distortion at any power level from 250 milliwatts to rated power output is 0.07%

### Input Sensitivity

0.4V for Rated Output

### A-Weighted Signal To Noise Ratio

115dB Below Rated Output

### Input Impedance

20,000 ohms

### Maximum Input Signal

9V

### Low Pass Filter

40 - 120Hz (Variable Control on the Rear Panel)

### Level Control

Variable Level Control on the Rear Panel

### Power Control In

5 - 20 VDC Trigger

### Power Requirements

100 Volts, 50/60Hz at 4.8 amps

110 Volts, 50/60Hz at 4.0 amps

120 Volts, 50/60Hz at 4.0 amps

220 Volts, 50/60Hz at 2.2 amps

230 Volts, 50/60Hz at 2.0 amps

240 Volts, 50/60Hz at 2.0 amps

### Overall Dimensions

Width is 15-1/8 inches (38.42cm)

Height is 15-1/2 inches (39.37cm)

Depth is 15 inches (38.10cm)

### Weight

87 lb. (39.50kg) net, 98 lb (44.5kg) in shipping carton

## Packing Instructions

In the event it is necessary to repack the equipment for shipment, the equipment must be packed exactly as shown below. Use banding straps to make sure box is held together securely.

Use the original shipping carton and parts only if they are in good serviceable condition. If a shipping carton or any of the interior part(s) are needed, please call or write Customer Service Department of McIntosh Laboratory. Please see the Part List for the correct part numbers.

<u>Quantity</u>	<u>Part Number</u>	<u>Description</u>
1	034287	Shipping carton Top
1	034286	Shipping carton Bottom
2	034288	Foam cap

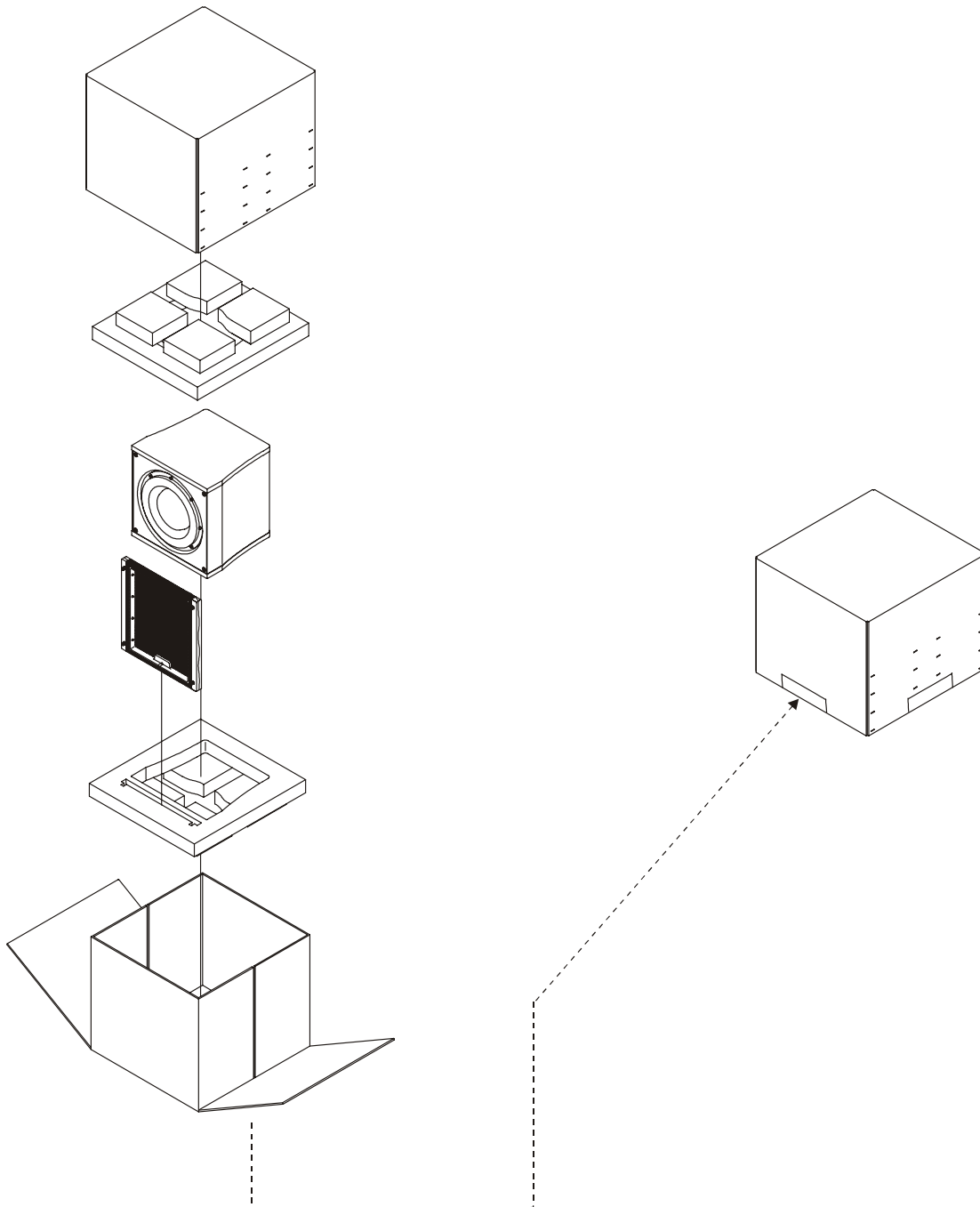



McIntosh Laboratory, Inc.  
2 Chambers Street  
Binghamton, NY 13903

The continuous improvement of its products is the policy of McIntosh Laboratory Incorporated who reserve the right to improve design without notice.

Printed in the U.S.A.

McIntosh Part No. 04092800